



Tailor-Made Protectivity™

FILLER METALS FOR  
REPAIR, ANTI-WEAR  
AND ANTI-CORROSION

---



voestalpine Bohler Welding India  
[www.voestalpine.com/welding](http://www.voestalpine.com/welding)

voestalpine

ONE STEP AHEAD.

# voestalpine Bohler Welding India

voestalpine Bohler Welding India Pvt. Ltd., is a fully owned subsidiary of voestalpine Bohler Welding GmbH for the region covering India, Sri Lanka, Nepal and Bangladesh. voestalpine Bohler Welding is associated with Indian market for past 40 years providing solutions for all welding jobs, services to all industries.

The sales company in India started in 2006, with its Head Office based out of Thane (near Mumbai) and Sales personnel spread across the Nation. In the last 20 years voestalpine Bohler Welding has spread its wings across industries and has an established distribution network to service the customers need.

### We provide expertise and know-how for the brands:

- » Bohler Welding
- » UTP Maintenance
- » Fontargen Brazing



With the acquisition in India in 2013, the company now has its own production facility based out of Bhiwadi, Rajasthan. Production facility in Bhiwadi focuses on supplying the Unalloyed, Medium alloyed and High alloyed stick electrodes. In past few years, investments have been put in improving the Quality standards, R&D and in New Product Development. With the inclusion of the World Class Flux Cored line, the company is also focussing on producing Unalloyed and hardfacing Flux Cored wires in India. With this facility, voestalpine Bohler Welding India is the first company in India to have European Technology based Flux cored line.

## Our India Network

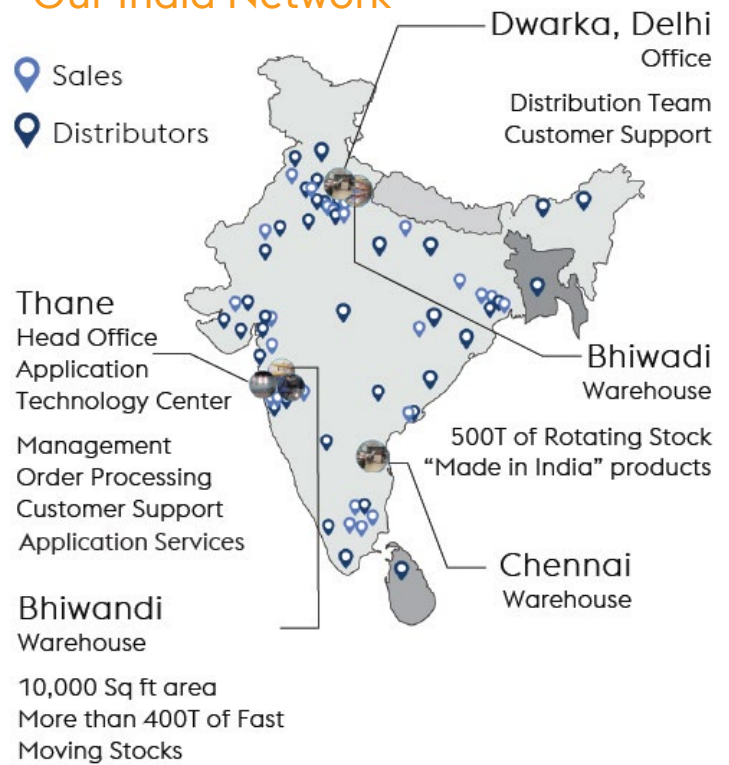

Our voestalpine Bohler Welding Application Technology Centre at Thane supports customers with specialised training programmes, local application support, product demonstrations and trials.



## Tailor-Made Protectivity™

UTP Maintenance ensures an optimum combination of protection and productivity with innovative and tailor-made solutions. Everything revolves around the customer and their individual requirements. That is expressed in the central performance promise: Tailor-Made Protectivity™.

With over 75 years of experience, UTP Maintenance is one of the pioneers in the field of nickel, hardfacing and special welding consumables. It has actively shaped the history of welding technology and will continue to do so in the future. Customers can rely on an experienced team of application engineers with profound metallurgical and process know-how for assistance. All products are tested and certified continuously in certified test laboratories at voestalpine Bohler Welding.

UTP Maintenance is your best choice for the following applications:

- » Repair welding
- » Hardfacing
- » Cladding
- » Thermal spraying and PTA

## Contents

|  |           |  |
|--|-----------|--|
| <b>Description</b> _____   | <b>2</b>  |  |
| <b>Corresponding filler metals</b> _____                           | <b>6</b>  |  |
| <b>Covered electrodes for repair of cracked material</b>           |           |  |
| Unalloyed and low alloy steels _____                               | 7         |  |
| Stainless Steels _____   | 7         |  |
| Nickel alloys _____  | 8         |  |
| Cast Iron _____  | 9         |  |
| Copper alloys _____  | 10        |  |
| Aluminum _____   | 10        |  |
| <b>Surfacing electrodes for anti-wear and anti-corrosion</b> _____ | <b>11</b> |  |
| <b>Surface Prepration Electrodes</b> _____                         | <b>17</b> |  |
| <b>TIG rods for repair of cracked material</b>                     |           |  |
| Stainless Steels _____   | 18        |  |
| Copper alloys _____  | 18        |  |
| Nickel alloys _____  | 18        |  |
|  |           | <b>Open arc cored wires for repair, anti-wear and anti-corrosion</b>                 |
|  |           | Manganese steels _____ 19  |
|  |           | Low alloy steels _____ 19  |
|  |           | High alloyed steels _____ 19   |
|  |           | <b>Submerged arc cored wires for anti-wear and anti-corrosion</b> _____ <b>21</b>    |
|  |           | <b>Submerged arc welding fluxes for anti-wear and anti-corrosion</b> _____ <b>21</b> |

# Business Product Lines

| Maintenance  |  | Cladding   |
|--|--|--|
| Repair product line  | Surfacing product line   | Cladding product line  |
| Repair of cracked material   | Anti-wear applications   | Anti-corrosion applications  |
| <ul style="list-style-type: none"> <li>» Covered Electrodes</li> <li>» TIG Rods</li> <li>» Solid Wires</li> <li>» Metal Cored Wires</li> <li>» Gas Shielded Cored Wires</li> <li>» Open Arc Wires</li> </ul> | <ul style="list-style-type: none"> <li>» Covered Electrodes</li> <li>» Solid Wires</li> <li>» Metal Cored Wires</li> <li>» Gas Shielded Cored Wires</li> <li>» Open Arc Wires</li> <li>» SAW-Wires</li> <li>» SAW-Flux</li> <li>» SAW-Cored Wires</li> <li>» Thermal Spraying Powders</li> </ul> | <ul style="list-style-type: none"> <li>» Covered Electrodes</li> <li>» TIG Rods</li> <li>» Solid Wires</li> <li>» Gas Shielded Cored Wires</li> <li>» Open Arc Wires</li> <li>» SAW-Flux</li> <li>» SAW-Cored Wires</li> <li>» SAW-Strips</li> <li>» Cladding Equipment</li> </ul> |

# Industry Focus



- » Agriculture & Food
- » Cement
- » Earth Moving
- » Energy & Power
- » Glass
- » Mining
- » Oil & Gas
- » Pulp & Paper
- » Pumps, Valves & Fittings
- » Railway Systems Recycling and Waste Management
- » Shipyards
- » Steel Structure
- » Steel Works
- » Sugar & Ethanol
- » Tool Construction

## Corresponding filler metals

| Covered Electrode | TIG Rod       | Solid wire    | Gas shielded cored wire     | Open Arc wire  | SAW Cored wire |
|-------------------|---------------|---------------|-----------------------------|----------------|----------------|
| UTP 610           | UTP A 118     | UTP A 118     |                             |                |                |
| UTP 611           |               | UTP A 119     |                             |                |                |
| UTP 614 KB        |               | UTP A 119     | UTP AF152                   | SK BU-C1       |                |
| UTP 63            | UTP A 63      | UTP A 63      | SK 402-G / SK 307-G         | SK 402-O       | SK 402-S       |
| UTP 68 LC         | UTP A 68 LC   | UTP A 68 LC   | UTP AF 68 LC                | SK 308L-O      |                |
| UTP 68 Mo         | UTP A 68 Mo   | UTP A 68 Mo   |                             |                |                |
| UTP 68 MoLC       | UTP A 68 MoLC | UTP A 68 MoLC |                             | SK 316L-O      |                |
| UTP 6824 LC       | UTP A 6824 LC | UTP A 6824 LC | UTP AF 6824 LC              | SK 309L-O      |                |
| UTP 068 HH        | UTP A 68 HH   | UTP A 68 HH   |                             |                |                |
| UTP 6222 Mo       | UTP A 6222 Mo | UTP A 6222 Mo |                             |                |                |
| UTP 83 FN         | UTP A 8051 Ti |               | SK FNM-G                    | SK FN-O        |                |
| UTP 86 FN         | UTP A 8051 Ti |               | SK FNM-G                    | SK FN-O        |                |
| UTP 387           | UTP A 387     | UTP A 387     |                             |                |                |
| UTP 34 N          | UTP A 34 N    | UTP A 34 N    |                             |                |                |
| UTP 73 G 2        | UTP A 73 G 2  | UTP A 73 G 2  | SK D 12-G / SK D 12S-G      |                |                |
| UTP 73 G 3        | UTP A 73 G 3  | UTP A 73 G 3  |                             |                |                |
| UTP 73 G 4        | UTP A 73 G 4  | UTP A 73 G 4  | SK 734-G                    | SK 734-O       |                |
| UTP 690           |               |               | SK 20-G                     |                |                |
| UTP 750           |               |               | SK D35-G                    |                | SK D 35-S      |
| UTP 7200          |               |               |                             | SK 313-O       |                |
| UTP BMC           |               |               | SK AP-G                     | SK AP-O        | SK AP-S        |
| UTP CELSIT 706    |               |               | SK STELKAY 6-G              | SK STELKAY 6-O |                |
| UTP CELSIT 721    |               |               | SK STELKAY 21-G             |                |                |
| UTP DUR 250       |               | UTP A DUR 250 | SK D250-G / SK 250-G        | SK BU-O        | SK BU-S        |
| UTP DUR 350       |               | UTP A DUR 350 | SK 350-G                    | SK 350-O       | SK 350-S       |
| UTP DUR 600       |               | UTP A DUR 600 | UTP AF DUR 600 T / SK 600-G | SK A12-O       |                |
| UTP LEDURIT 61    |               |               |                             | SK 460-O       |                |
| UTP LEDURIT 65    |               |               |                             | SK A45-O       | SK A45-S       |

# Covered electrodes for repair of cracked material

Unalloyed and low alloy steels

| Product Name<br>Classification AWS<br>Classification EN<br>Classification DIN                | Mechanical Properties<br>Typical Values                         | Size (mm)  | Approvals                   | Characteristics and Applications  |
|--|---|--|-----------------------------|---|
| <b>UTP 613 kb</b><br><br>AWS A5.1:<br>~ E 7018-1 H4 R<br><br>EN ISO 2560-A:<br>E 42 5 B42 H5 | UTS: >510 MPa<br>YS: >420 MPa<br>El: >25%<br>CVN Impact: >120J  | 2.5 x 350<br>3.2 x 350<br>4.0 x 350<br>5.0 x 450   | TÜV, DB,<br>ABS, BV,<br>DNV | UTP 613 Kb is a basic-coated stick electrode for construction-, boiler-, tube- and fine-grained steels as well as for steels with up to 0.35% C-content.<br>UTP 613 Kb has a good weldability and a stable arc. The weld metal is resistant to ageing, crack-resistant and is little affected by steel impurities.                                  |
| <b>LOTUS - 24</b>  | UTS: 520 - 600 MPa<br>El: 25 - 32%<br>CVN Impact:<br>27°C: 190J | 2.50 x 350<br>3.15 x 350<br>4.0 x 350<br>5.0 x 350 | -                           | High strength welds deposit and minimum distortion. Smooth weld bead of X-ray quality. Weld bead with fine ripples and easy slag removal. Suitable for low & medium carbon steels. Excellent mechanical properties including impact strength.<br>Applications: Flanges, crane girders, shovel boom, dumper chassis and heavy equipment maintenance. |

## Stainless Steels

| Product Name<br>Classification AWS<br>Classification EN<br>Classification DIN       | Mechanical Properties<br>Typical Values                                | Size (mm)   | Approvals | Characteristics and Applications  |
|---|--|---|-----------|---|
| <b>UTP S 63</b><br><br>AWS A5.4:<br>E307-16<br><br>EN ISO 3581-A:<br>E 18 8 Mn R 32 | UTS: >600 MPa<br>YS: >350 MPa<br>El: >40%<br>CVN Impact:<br>+20°C: 60J | 2.50 x 350<br>3.25 x 350<br>4.00 x 350<br>5.00 x 450  | -         | Non alloy structural and heat treatable steels can be welded, also in combination with austenitic CrNi steels. Universally applicable for surfacing of work pieces exposed to impact, pressure and rolling wear. Such as curved rails, crusher parts, and excavator teeth. Provides crack-proof buffer layers under hard alloys. Weld deposit resist to scaling, rust and cracks, work hardened. Hardness of the pure weld metal<br>As welded: 190 HB   After work hardened: 250 HB   |
| <b>UTP 65 D</b><br><br>EN ISO 3581-A:<br>E Z 29 9 R 12<br><br>EN 14700:<br>E Z Fe11 | UTS: >800 MPa<br>YS: >640 MPa<br>El: >20%                              | 1.6 x 250*<br>2.0 x 250<br>2.5 x 250<br>3.2 x 350<br>4.0 x 350<br>5.0 x 350<br>* available on request | -         | UTP 65 D has been developed to meet the highest requirements for repair and surfacing. It is extremely crack-resistant when joining steels of difficult weldability, such as e. g. hard manganese steels, tool steels, spring steels, high speed steels as well as dissimilar metal joints. Due to the good corrosion and abrasion resistance and high tensile strength. UTP 65 D finds its application particularly in repair and maintenance of machine and drive components, such as gears, cams, shafts, hot cuts, hot trim plates and dies. Also ideally suited as an elastic cushioning layer for very hard surfacings. |

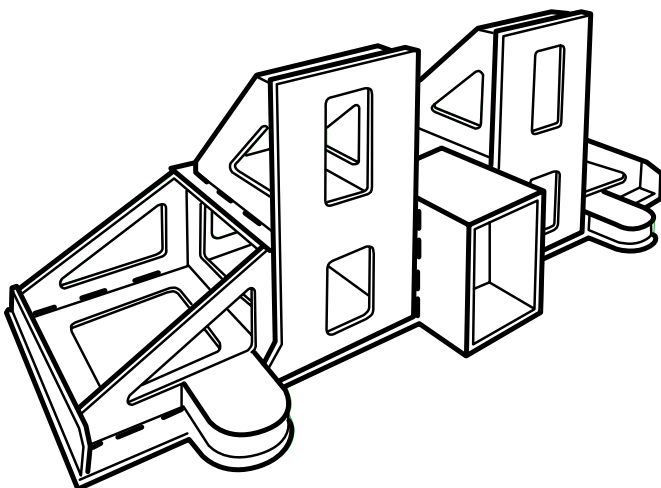

## Stainless Steels

| Product Name<br>Classification AWS<br>Classification EN<br>Classification DIN | Mechanical Properties<br>Typical Values | Size (mm)  | Approvals | Characteristics and Applications  |
|---|---|--|-----------|---|
| <b>LOTUS-32</b>   | UTS: 700 - 800 MPa<br>El: 20 - 25%      | 2.50 x 350<br>3.15 x 350<br>4.0 x 350<br>5.0 x 350 | -         | Weld deposit contains 40-50 % ferrite. Controlled grain structure. Superior crack resistance and ductile. Excellent weldability with all stainless steels with known & unknown composition. Good resistance to corrosion, friction, heat and impact. Applications: Tools, dies, gears, pinions, shafts, joining dissimilar steels, machinable build up and overlay. |
| <b>LOTUS-39</b>   | UTS: 550 - 650 MPa<br>El: 30 - 42%      | 2.50 x 350<br>3.15 x 350<br>4.0 x 350<br>5.0 x 350 | -         | Ideal for oxidation and heat resistance up to 1200°C. Suitable for welding of unknown composition steel and AISI 309. Dissimilar welding of mild steel, low alloy steel and stainless steel possible. Applications: Heat exchangers, valves, furnace parts, heat treatment plants, tanks and baskets.   |

## Nickel Alloys

| Product Name<br>Classification AWS<br>Classification EN<br>Classification DIN                               | Mechanical Properties<br>Typical Values                           | Size (mm)   | Approvals                           | Characteristics and Applications  |
|---|---|---|-------------------------------------|---|
| <b>UTP 68H</b><br><br>AWS A5.4:<br>E 310-16<br><br>EN ISO 3581-A:<br>E 25 20 R 32                           | UTS: > 550 MPa<br>YS: >350 MPa<br>El: >30%<br>CVN Impact:<br>>47J | 2.50 x 350<br>3.25 x 350<br>4.00 x 400                        | -                                   | The rutile coated stick electrode UTP 68 H is suitable for joining and surfacing of heat resistant Cr-, CrSi-, CrAl-, CrNi-steels/cast steels. It is used for operating temperatures up to 1100° C in low sulphur combustion gas. Application fields are in the engineering of furnaces, pipework and fittings. UTP 68 H is weldable in all positions except vertical down. Fine droplet. The surface of the seams is smooth and finely rippled. Easy slag removal free from residues.  |
| <b>UTP 068 HH</b><br><br>AWS A5.11:<br>E NiCrFe-3 (mod.)<br><br>EN ISO 14172:<br>E Ni 6082<br>(NiCr20Mn3Nb) | UTS: >620 MPa<br>YS: >390 MPa<br>El: >35%<br>CVN Impact: >80J     | 2.5 x 300<br>3.2 x 300<br>4.0 x 350                           | TÜV                                 | UTP 068 HH is predominantly used for joining identical or similar heat-resistant Ni-base alloys, heat-resistant austenites, such as 2.4817 (LC NiCr15Fe), 1.4876 (X10 NiCrTiAl 32 20), 1.4941 (X8 CrNTi 18 10). Specially used for joining of high carbon containing 25/35 CrNi cast steel to 1.4859 or 1.4876 for petrochemical installations with working temperatures up to 900°C. Furthermore UTP 068 HH can be used for repair welding of hardly weldable steels such as heat-treatable steels or tool steels. Additionally mixed joints of austenitic and ferritic materials with elevated service temperatures can be welded. The welding deposit of UTP 068 HH is hot-cracking-resistant, does not tend to embrittlement and is scale-resistant at high temperatures. |
| <b>UTP 6222 Mo</b><br><br>AWS A5.11:<br>ENiCrMo-3<br><br>EN ISO 14172:<br>E Ni 6625<br>(NiCr22Mo9Nb)        | UTS: >760 MPa<br>YS: >450 MPa<br>El: >30%<br>CVN Impact: >75J     | 2.5 x 300<br>3.2 x 300<br>3.2 x 350<br>4.0 x 350<br>5.0 x 400 | TÜV (No. 03610),<br>DNV, ABS,<br>BV | UTP 6222 Mo is particularly suited for joining and surfacing on nickel alloys, austenitic steels, low temperature nickel steels, austenitic-ferritic-joints and claddings of the same or similar nature, like 2.4856 (NiCr22Mo 9 Nb), 1.4876 (X30 NiCrAlTi 32 20), 1.4529 (X2 NiCrMoCu 25 20 5). The weld metal is heat resistant and suitable for operating temperatures up to 1000 °C. It must be noted that a slight decrease in ductility will occur if prolonged heat treatment is given within the temperature range 600 – 800 °C. Scale-resisting in low-sulphur atmosphere up to 1100 °C. High creep strength.  |

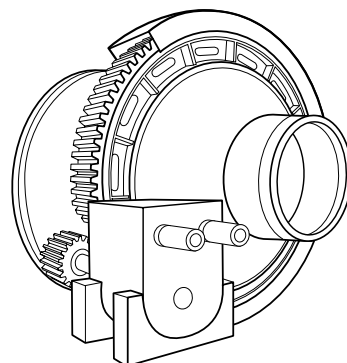
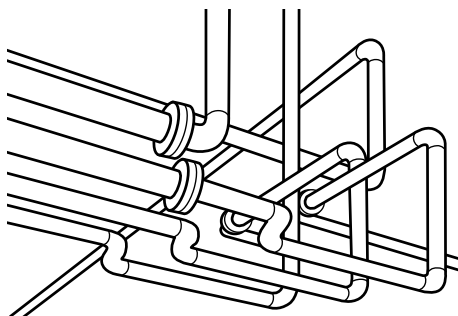



## Cast Iron

| Product Name<br>Classification AWS<br>Classification EN<br>Classification DIN | Mechanical Properties<br>Typical Values | Size (mm)                              | Approvals | Characteristics and Applications   |
|---|---|--|-----------|--|
| <b>UTP N 815 C</b>  | UTS: 350 MPa                            | 2.50 x 350<br>3.15 x 350<br>4.00 x 350 | -         | <p>UTP N 815 C is Nickel electrode suitable for welding of grey and malleable cast iron, cast steel and especially for repair and maintenance. This electrode has excellent welding properties with smooth bead, easy slag removal and minimum spatter.</p> <p>Superior for thin walled grey cast iron.</p> <p>Excellent for building up missing sections, cladding, filling holes, repairing broken, cracked and fabrication of cast iron to other metals. Suitable for vertical and overhead work.</p> <p>Outstanding features are -</p> <ul style="list-style-type: none"> <li>• Ideal for cladding application</li> <li>• Minimal base metal penetration and dilution</li> </ul> <p>Applications: Engine blocks (water jacket), cast iron gears and pulleys, sliding tables for machine tools.</p> |
| <b>UTP N 819 FN</b>   | UTS: 430 MPa<br>YS: 380 MPa             | 2.50 x 350<br>3.15 x 350<br>4.00 x 350 | -         | <p>UTP N 819 FN is Ferro Nickel electrode with approx. 55% Ni in weld metal suitable for joining and surfacing lamellar grey cast iron, nodular cast iron and malleable cast iron as well as for joining these materials with each other or with steel or cast steel. Applicable for repair, construction and production welding.</p> <p>It has excellent buttering characteristic on cast iron. This electrode has stable arc and produces a flat seam structure without undercutting. The bead appearance is smooth. The weld deposit is highly crack resistant and easily machinable with cutting tools.</p> <p>The current carrying capacity and the deposition rate are excellent.</p> <p>Applications: Nodular Iron castings, housings, foundry defects, cast iron die cladding and build-up</p> |
| <b>UTP N 817</b>  | -                                       | 2.50 x 350<br>3.15 x 350<br>4.0 x 350  | -         | <p>UTP N 817 is non machinable cast iron electrode suited for pickup layers on poorly weldable cast iron as a base for a secondary weld with pure Nickel or Ferro Nickel stick electrode. Wear surfacing can also be performed with one pass weld.</p> <p>For all cast iron repair welding not requiring machining. Weld metal cracking tendencies are greatly minimized. Nickel free deposits and its colour matches with cast iron. Suitable for all types of sections, thick and thin and for joining of cast iron to steel.</p> <p>Applications: Sealing oil-soaked cast iron parts, defects, cast iron furnace equipment.</p>   |

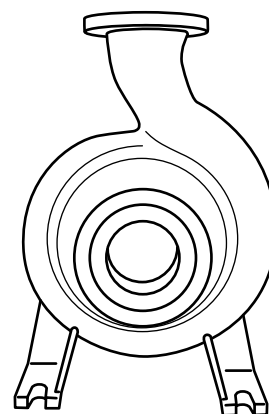
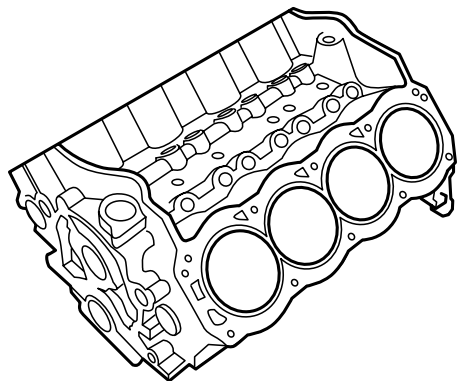

## Copper alloys

| Product Name<br>Classification AWS<br>Classification EN<br>Classification DIN | Mechanical Properties<br>Typical Values   | Size (mm)                            | Approvals | Characteristics and Applications  |
|---|---|--------------------------------------|-----------|---|
| <b>LOTUS 51</b>   | -   | 3.15 x 350<br>4.0 x 350<br>5.0 x 350 | -         | Light coated electrode with graphite base. Designed for welding of Copper and Bronze. Deposit is porosity free & machinable. Suitable for cladding also. Dissimilar welding between MS, phosphorus bronze & brass possible. Applications: Pump casting, casting sleeves, impellers, marine components, bus bars, propellers etc.  |
| <b>UTP 32</b>   | YS : 300 MPa<br>El : 25%                  | 2.5 x 300<br>3.2 x 350<br>4.0 x 350  | -         | UTP 32 is a basic-coated tin-bronze stick electrode for joining and surfacing on copper tin alloys with 6 – 8 % Sn, copper-tin alloys and for weld claddings on cast iron materials and on steel.<br>UTP 32 is easily weldable, good slag removal. The corrosion-resistance is corresponding to identical or similar base metals. Good gliding properties.  |
| <b>UTP 34 N</b>   | UTS : 650 MPa<br>YS : 400 MPa<br>El : 15% | 2.5 x 350<br>3.2 x 350<br>4.0 x 350  | DB        | UTP 34 N is suitable for joinings and surfacings on copper-aluminium alloys, especially with high Mn-content as well as for claddings on cast iron materials and steel. Main application fields are in the shipbuilding (propeller, pumps, armatures) and in the chemical industry. The good friction coefficient permits claddings on shafts, bearings, stamps, drawing tools and all kind of gliding surface.<br>UTP 34 N has excellent welding properties, spatter-free welding, good slag removal. The weld deposit has high mechanical values, a good corrosion resistance in oxidizing media, best gliding properties and a very good machinability. Crack resistant and pore-free. |

## Aluminium

| Product Name<br>Classification AWS<br>Classification EN<br>Classification DIN | Mechanical Properties<br>Typical Values | Size (mm)  | Approvals | Characteristics and Applications   |
|---|---|--|-----------|--|
| <b>UTP 48</b><br><br>DIN 1732:<br>EL-AISi12                                   | UTS: 180 MPa<br>YS: 80 MPa<br>El: 5%    | 2.5 x 355*<br>3.2 x 355*<br>4.0 x 355*<br>* available on request | -         | UTP 48 is a aluminium stick electrode with 12% Si and a special coating for joining and surfacing on aluminium-silicon casting alloys with a Si-content up to 12% Si according to DIN 1725 e.g.<br>3.2581 G- AISi12   3.2583 G- AISi12(Cu)<br>3.2383 G- AISi10Mg(Cu)   3.2381 G- AISi10Mg<br>3.2373 G- AISi9Mg |

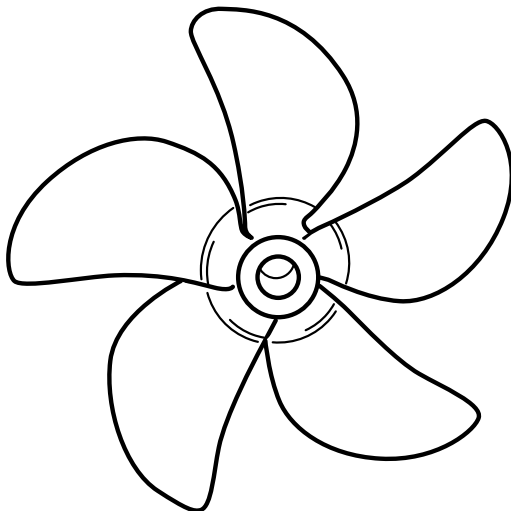

# Surfacing electrodes for anti-wear and anti-corrosion

| Product Name<br>Classification AWS<br>Classification EN<br>Classification DIN | Mechanical Properties<br>Typical Values | Size (mm)  | Approvals | Characteristics and Applications   |
|---|---|--|-----------|--|
| <b>UTP 73 G 2</b>   | Hardness:<br>55 - 58 HRC                | 2.5 x 300<br>3.2 x 350<br>4.0 x 400<br>5.0 x 400                           | -         | UTP 73 G 2 is, due to its high hardness, toughness and heat resistance ideally suited for buildups on parts subject to severe friction, compression and moderate impact loads at elevated temperatures, such as back centers, gripping pliers, gliding and guiding surfaces, hot and cold punching tools, valves, slides, hot-shear blades, extrusion press pistons, forging tools, stripping columns, trimming tools, roll mandrils, punching tools for sheet metals. UTP 73 G 2 is used to good advantage for the production of new cold and hot working tools. In such cases cladding is made on base material with an accordingly high tensile strength.<br>The stick electrode has excellent welding properties, a stable and regular flow, good bead appearance and very easy slag removal. Heat resistant up to 550° C. |
| <b>UTP 73 G 3</b><br><br>EN 14700:<br>E Fe3<br><br>DIN 8555:<br>E 3-UM-45-T   | Hardness:<br>approx. 45 – 50 HRC        | 2,5 x 300<br>3,2 x 350<br>4,0 x 400<br>5,0 x 400*<br>*available on request | -         | UTP 73 G 3 is, due to its high strength, toughness and heat resistance ideally suited for buildups on parts subject to friction, compression and impact at elevated temperatures, such as hot shears blades, gate shear, forging saddles, hammers, forging dies, Al-die cast moulds. UTP 73 G 3 is also used to good advantage for the production of new cold and hot working tools with low-alloy base materials. The stick electrode has excellent welding properties, a stable and regular flow, good bead appearance and very easy slag removal. Heat resistant up to 550°C. Hardness of the pure weld metal: approx. 45 – 50 HRC  |
| <b>UTP N 2714 DS</b>  | Hardness:<br>41- 43 HRC                 | 4.00 x 450<br>5.00 x 450<br>6.30 x 450                                     | -         | Low hydrogen heavy coated electrode for all conventional position welding and repair. Deposits medium alloyed weld metal of radiographic quality. Excellent welding characteristic with less spatter and self-lifting slag. Superior creep resistance and impact toughness. Cobalt helps to increase resistance against abrasion, compression and impact at elevated temperature. Weld deposit is machinable by carbide tools. Repair of cracks in Ni- Cr hot working dies and case hardening steel.<br>Applications:<br>Build-up & Surfacing on all drop & press forging dies, hammers, punches, inserts. Repairs on hot working tools, forging dies, press jacks, hot draw rings, hot cutting and up setting tools. Suitable for surfacing on edges of tools from low & alloyed high tensile steels, hardened surfaces etc.  |

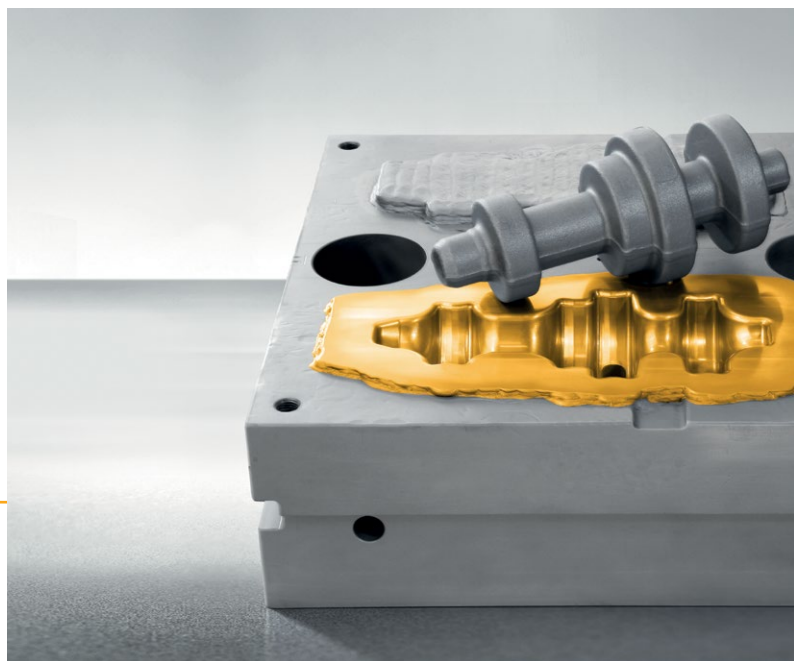

## Surfacing electrodes for anti-wear and anti-corrosion

| Product Name<br>Classification AWS<br>Classification EN<br>Classification DIN  | Mechanical Properties<br>Typical Values  | Size (mm)  | Approvals | Characteristics and Applications   |
|--|--|--|-----------|--|
| <b>UTP 690</b><br><br>AWS A5.13:<br>E Fe 5-B (mod.)<br><br>EN 14700:<br>E Fe4<br><br>DIN 8555:<br>E 4-UM-60-ST           | Hardness:<br>approx. 62 HRC  | 2.5 x 350<br>3.2 x 350<br>4.0 x 450              | -         | UTP 690 is used for repair and production of cutting tools, particularly for building-up cutting edges and working surfaces. The deposit is highly resistant to friction, compression and impact, also at elevated temperatures up to 550°C. The production of new tools by welding on non-alloy and low alloy base metals is also possible (cladding of cutting edges). UTP 690 has excellent welding properties, a smooth, finely rippled bead appearance due to the spray arc and very easy slag removal. The weld deposit is equivalent to a high speed steel with increased Mo-content. |
| <b>UTP S 718 S</b><br><br>EN 14700:<br>E Fe14<br><br>DIN 8555:<br>E 10-UM-60-G   | Hardness:<br>approx. 60 HRC  | 3.25 x 350<br>4.00 x 450<br>5.00 x 450           | -         | This electrode is designed especially to meet rougher the sugar milling rolls by applying a hard coating in the form of small globules in the surface of the teeth of the mass reducing thus dramatically the sugarcane slippage. This electrode has a specially designed flux as characterized by a rapid ignition and re-ignition, needed to cross the discontinuities caused by grooving of the masses. Its hard coat globules deposit, have the right size for a good drag of the sugarcane, without having to open the combs.   |
| <b>UTP 7200</b><br><br>AWS A5.13:<br>EFeMn-C<br><br>EN 14700:<br>EZ Fe9<br><br>DIN 8555:<br>~ E 7-UM-250-KP              | Hardness as welded:<br>200 – 250 HB<br>Hardness after work-hardening:<br>48 – 53 HRC | 3.2 x 350<br>4.0 x 450<br>5.0 x 450              | DB        | UTP 7200 is suitable for tough and crack-resistant joinings and surfacings on parts of high Mn-steel subject to extreme impact, compression and shock. Build-ups on C-steel are also possible. The main application is in construction, in quarries and mines for surfacing worn high-Mn steel parts, e.g. excavator pins, buckets and teeth, mill hammers, crusher jaws and cones, rails, crossings and switches.   |
| <b>UTP LEDURIT 61</b><br><br>AWS A5.13:<br>EFeCr-A8 (mod.)<br><br>EN 14700:<br>E Fe14<br><br>DIN 8555:<br>E 10-UM-60-GRZ | Hardness:<br>approx. 60 HRC  | 2.5 x 350<br>3.2 x 350<br>4.0 x 450<br>5.0 x 450 | -         | UTP LEDURIT 61 is suited for highly wear resistant claddings on parts subject to strong grinding abrasion combined with medium impact, such as conveyor screws, scraper blades, bucket teeth, mixer wings, sand pumps. Also as a final layer on crusher jaws. Welding properties: UTP LEDURIT 61 has excellent welding characteristics and a very easy slag removal. The homogeneous and finely rippled seam surface does, for most applications, not require any finishing by grinding.   |

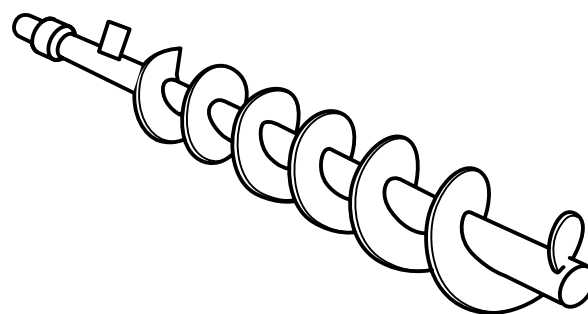

# Surfacing electrodes for anti-wear and anti-corrosion

| Product Name<br>Classification AWS<br>Classification EN<br>Classification DIN       | Mechanical Properties<br>Typical Values                               | Size (mm)  | Approvals | Characteristics and Applications  |
|---|---|--|-----------|---|
| <b>UTP LEDURIT 65</b><br><br>EN 14700:<br>E Fe16<br><br>DIN 8555:<br>E 10-UM-65-GRZ | Hardness:<br>approx. 65 HRC   | 3.2 x 350<br>4.0 x 450<br>5.0 x 450                  | -         | UTP LEDURIT 65 is suited for highly abrasion resistant claddings on parts subject to extreme sliding mineral abrasion, also at elevated temperatures up to 500°C. The extremely high abrasion resistance is reached by the very high content of special carbides (Mo, V, W, Nb). Main application fields are surfacings on earth moving equipment, working parts in the cement and brick industry as well as in steel mills for radial breakers and revolving-bar screens of sintering plants. UTP LEDURIT 65 has an even droplet transfer in the spray arc. The smooth welding bead is without slag covering. In general there is no need for any finishing by grinding. |
| <b>UTP S BMC</b><br><br>EN 14700:<br>E Fe9<br><br>DIN 8555:<br>E 7-UM-250-KPR       | Hardness as welded: 260 HB<br>Hardness after work hardened: 48-53 HRC | 3.25 x 350<br>4.0 x 450<br>5.0 x 450                 | -         | Suitable for build-up and claddings on part subject to highest pressure and shock in combination with abrasion. Surfacing can be made on ferritic steel as well as austenitic hard Mn-steel and joints on hard Mn-steel can be welded. Main application are in the mining, cement, crushing plant, steel works, thermal power plant where working parts are regenerated, such as breaker jaws, frogs, cross pieces, paving breakers, crusher hammer & rotors, railway points & crossing, etc. Rapid work hardening and high toughness.  |
| <b>UTP S DUR 350</b><br><br>EN 14700:<br>E Fe 1<br><br>DIN 8555:<br>E 1-UM-350      | Hardness:<br>380 HB   | 3.25 X 350<br>4.00 x 450<br>5.00 X 450               | -         | Good abrasion resistance and multi-layer build up ability. Particularly suited for wear resistant surfacing on Mn-Cr-V alloyed parts, such as frogs, track rollers, chain support rolls, sprocket wheels, guide rolls etc. Weld metal is machinable with tungsten carbide tools.  |
| <b>UTP S DUR 600</b><br><br>EN 14700:<br>E Fe8<br><br>DIN 8555:<br>E6-UM-60         | Hardness:<br>55 HRC   | 2.50 x 350<br>3.25 x 350<br>4.00 x 450<br>5.00 x 450 | -         | Martensitic microstructure with good resistance to abrasion, impact and compression. Universally applicable for cladding parts of steels, cast steels and high Mn-steel, subjected a simultaneously to abrasion, impact and compression. Typical application fields are the earth moving and stone treatment industry, e.g. excavator bucket teeth, crusher jaws and cones, mill hammers, rotors, etc. Good weldability and easy slag removal, machining of the weld metal possible by grinding only.   |
| <b>UTP S DUR 650 kb</b><br><br>EN 14700:<br>E Fe8<br><br>DIN 8555:<br>E 6-UM-60     | Hardness:<br>57 – 60 HRC  | 3.25 X 450<br>4.00 x 450<br>5.00 X 450               | -         | UTP S DUR 650 Kb is suitable for cladding structural parts subject to abrasion combined with impact. The main applications are tools in the earth moving industry and crushing plants as well as cold and hot working tools. The deposit is only machinable by grinding. UTP S DUR 650 Kb is a martensitic alloy. The stick electrode is suited in impact a pressure stress situations. Machining of the weld metal only by grinding.   |

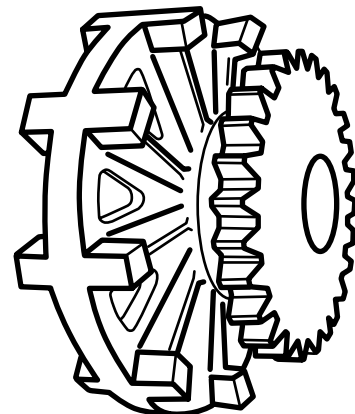
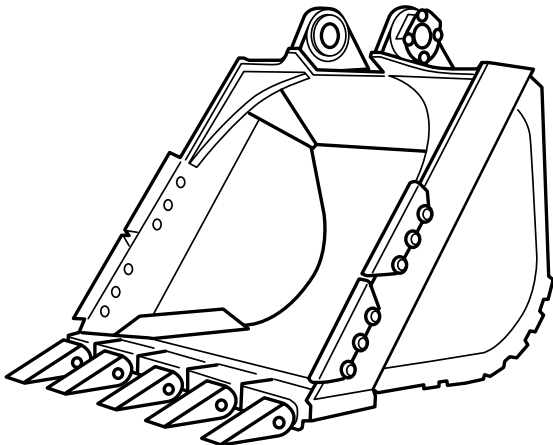

# Surfacing electrodes for anti-wear and anti-corrosion

| Product Name<br>Classification AWS<br>Classification EN<br>Classification DIN | Mechanical Properties<br>Typical Values                                    | Size (mm)                            | Approvals | Characteristics and Applications   |
|---|--|--------------------------------------|-----------|--|
| <b>HARDALOY - II</b>  | Hardness 2 layer:<br>36 - 40 HRC   | 3.15 x 450<br>4.0 x 450<br>5.0 x 450 | -         | A hard facing electrode for mild steel, carbon steel and low alloy steels, where 350 Brinell hardness is required. The weld deposit is highly resistant to abrasive wear with good toughness properties. With the help of carbide tools weld deposit is machinable. Weld deposit provides good combination of abrasion and impact properties. Suitable for the surfacing on couplings, cog wheels, cold punching dies, rail ends and crossing, steel castings, excavators, conveyors parts, wobbler ends, Cams, Gear Shaft, Shear blades etc.  |
| <b>HARDALOY - III</b>   | Hardness 2 layer:<br>57 - 60 HRC   | 3.15 x 450<br>4.0 x 450<br>5.0 x 450 | -         | Rutile coated type air hardening electrode for surfacing applications on mild steel, carbon steel and low alloy steel where 550 Brinell hardness is required. The welds are non-machinable and can only be ground. Slag is easily detachable. Deposit provides resistance against high abrasion and moderate impact. Used for surfacing on metal cutting and forming tools, shears, croppers, oil expellers, cane cutting knives, conveyor buckets and mixer blades, crane wheels, bulldozer blades etc. Deposit should not be more than 2-3 layers.<br>In difficult steel/carbon steel cushioning layers is recommended using ULTRA 7016. |
| <b>HARDALOY - III LH</b>  | Hardness 2 layer:<br>56 -58 HRC  | 3.15 x 450<br>4.0 x 450<br>5.0 x 450 | -         | Basic heavy coated air hardening type electrode specially designed for hard facing and build - up on worn out machine parts which are subjected to extremely severe service conditions involving a combination of impact and abrasion. The weld deposit is hard, tough and non machinable. Used for surfacing on bamboo chipper knives, crushers, cane cutting knives, punches dies, drilling bits, shears, bulldozer blades, bucket lip and surfacing/ rebuilding of mill hammers for pulverizing coat etc. Deposit should not exceed more than two layers.   |
| <b>HARDALOY - V</b>   | Hardness 2 layer:<br>58 HRC  | 3.15 x 450<br>4.0 x 450<br>5.0 x 450 | -         | A medium heavy coated basic type graphite coated electrode for hard-facing and build-up of worn out machine parts and components. Weld beads are flat and smooth. Slag easily detachable. The weld metal is alloyed cast iron which is hard and extremely resistant to abrasion and metal to metal wear. Suitable for the surfacing on dredger bucket lips, oil expeller worms, concrete mixture blades, scrapper blades, screw conveyor, cement die rings etc. Deposit should not exceed more than 2- 3 layers.   |
| <b>HARDALOY - Mn</b>  | Hardness as deposited:<br>180 - 220 BHN<br>Work hardness:<br>up to 500 BHN | 3.15 x 450<br>4.0 x 450<br>5.0 x 450 | -         | Hardaloy-Mn is a medium heavy coated basic type austenitic manganese (12-14%) steel electrode specially designed for re-conditioning of austenitic manganese steel parts. The weld metal has good resistance to wear under severe impact. Weld deposit is work hardenable for high impact applications. Suitable for the surfacing on crusher jaw, manganese steel rails, rail cross-over, cement grinding rings, austenitic manganese steel casting and hammers, crusher mantles etc.   |

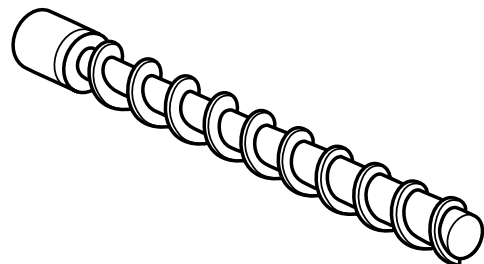
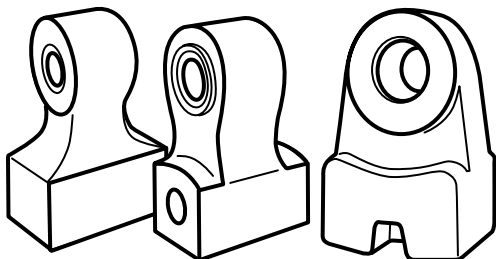

## Surfacing electrodes for anti-wear and anti-corrosion

| Product Name<br>Classification AWS<br>Classification EN<br>Classification DIN | Mechanical<br>Properties<br>Typical Values                               | Size<br>(mm)                         | Approvals | Characteristics and Applications   |
|---|--|--------------------------------------|-----------|--|
| <b>LOTUS - 71 B</b>   | Hardness as deposited:<br>220 -280 BHN<br>Work hardness:<br>upto 500 BHN | 3.15 x 350<br>4.0 x 350<br>5.0 x 350 | -         | Excellent toughness and exceptional resistance to cracking. Work hardens while in service. Long life under heavy impact. Ideal for buffer layer on Mn steel before hard facing. Applications: Points and crossings, frogs, switches, dredger, excavator parts. Joining Mn steel to itself and carbon steels.                     |
| <b>LOTUS - 72</b>   | Hardness as deposited: 280-320 BHN on 2 layer                            | 3.15 x 350<br>4.0 x 350<br>5.0 x 350 | -         | Weld deposit is machinable. Overlay on ferrous materials. Good toughness and resistance to deformation. Rapid deposition in all position. Applications: Hammers, wobblers, excavators, sprockets, rollers, shafts, gear teeth and forging dies.  |
| <b>LOTUS - 73</b>   | Hardness as deposited: 550 - 600 BHN on 3 layer                          | 3.15 x 350<br>4.0 x 350<br>5.0 x 350 | -         | Superior dense and spatter free deposit. Resist high abrasion and moderate impact. Operative in all positions. Suitable for reclamation and protective coating. Unique electrode for multiples build up in all positions. Applications: Buckets, shovels, excavating equipment, plough shears, scrapper, and conveyor screw etc. |
| <b>LOTUS-76</b>   | Hardness as deposited: 580 - 640 BHN on 3 layer                          | 3.15 x 350<br>4.0 x 350<br>5.0 x 350 | -         | Chromium carbide deposit retains sharp edge. Highly resistant to abrasion and moderate impact. Air hardening weld deposit. Applications: Paper cutting knives, cane cutting knives, pump casings, hammers, jaw plates, bucket pads, lips teeth, screw conveyor used in sugar, cement and mining industries.                      |
| <b>LOTUS 766</b>  | Hardness as deposited: 570 - 610 BHN on 3 layer                          | 3.15 x 350<br>4.0 x 350<br>5.0 x 350 | -         | High abrasion resistant with moderate impact. Excellent compressive strength. Air hardening weld deposit. Suitable for very high abrasion with mild impact applications. Applications: Augers, screws, conveyors, scrappers, paddle and wear pads etc. of sugar, cement and mining industries.                                   |

## Surfacing electrodes for anti-wear and anti-corrosion

| Product Name<br>Classification AWS<br>Classification EN<br>Classification DIN                                       | Mechanical Properties<br>Typical Values                   | Size (mm)   | Approvals | Characteristics and Applications   |
|---|---|---|-----------|--|
| <b>UTP CELSIT 701</b><br><br>AWS A5.13:<br>E CoCr-C<br><br>EN 14700:<br>E Co3<br><br>DIN 8555:<br>E 20-UM-55-CSTZ   | Hardness:<br>54 - 56 HRC                                  | 3.2 x 350<br>4.0 x 350  | -         | UTP CELSIT 701 is suited for highly wear resistant hardfacing on parts subject to severe abrasion in combination with corrosion and high temperatures up to 900°C, such as working parts in the chemical industry, running and sealing faces on fittings, valve seats and cones for combustion engines, cutting and crushing tools, hot working tools exposed to severe stresses without thermal shock, milling, mixing and drilling tools. Excellent gliding characteristics, good polishability, slightly magnetic.  |
| <b>UTP CELSIT 706</b><br><br>AWS A5.13:<br>E CoCr-A<br><br>EN 14700:<br>E Z Co2<br><br>DIN 8555:<br>E 20-UM-40-CSTZ | Hardness:<br>40 - 42 HRC                                  | 3.2 x 350<br>4.0 x 350<br>5.0 x 350*<br>*available on request | -         | UTP CELSIT 706 is used for hardfacing on parts subject to a combination of erosion, corrosion, cavitation, impact, pressure, abrasion and high temperatures up to 900°C, such as tight surfaces on fittings, valve seats and cones for combustion engines, gliding surfaces metal-metal, highly stressed hot working tools without thermal shock, milling mixers and drilling tools. Excellent gliding characteristics, easy polishability, good toughness, nonmagnetic. Machining by grinding or with tungsten carbide cutting tools. UTP CELSIT 706 has excellent welding properties and a homogenous, finely rippled seam due to spray arc. Very easy slag removal. |
| <b>UTP CELSIT 712</b><br><br>AWS A5.13:<br>E CoCr-B<br><br>EN 14700:<br>E Co3<br><br>DIN 8555:<br>E 20-UM-50-CSTZ   | Hardness at RT:<br>48 - 50 HRC                            | 3.2 x 350<br>4.0 x 350  | -         | UTP CELSIT 712 is used for highly wear resistant hardfacing on parts subject to a combination of abrasion, erosion, cavitation, corrosion, pressure and high temperatures up to 900°C, such as running, sealing and gliding faces on fittings and pumps, tools for wood, paper, plastic, shredding tools, highly stressed hot working tools without thermal shock. UTP CELSIT 712 has excellent welding properties and a homogeneous, finely rippled seam. Very easy slag removal.   |
| <b>UTP CELSIT 721</b><br><br>AWS A5.13:<br>E CoCr-E<br><br>EN 14700:<br>E Co1<br><br>DIN 8555:<br>E 20-UM-350-CTZ   | Hardness: 31 - 37 HRC<br>Work-hardened:<br>approx. 45 HRC | 3.2 x 350<br>4.0 x 350  | -         | UTP CELSIT 721 is used for crack-resistant hardfacings on parts subject to a combination of pressure, impact, abrasion, corrosion and high heat up to 900°C, such as running and sealing faces of gas, water, steam and acid fittings and pumps, valve seats and cones for combustion engines, working parts on turbines and power plants, hot working tools with frequent changes of high thermal load. Excellent gliding characteristics, good polishability and toughness, highly work-hardening, nonmagnetic, machinable with cutting tools. UTP CELSIT 721 has excellent welding properties and a homogenous, finely-rippled seam. Very easy slag removal.        |

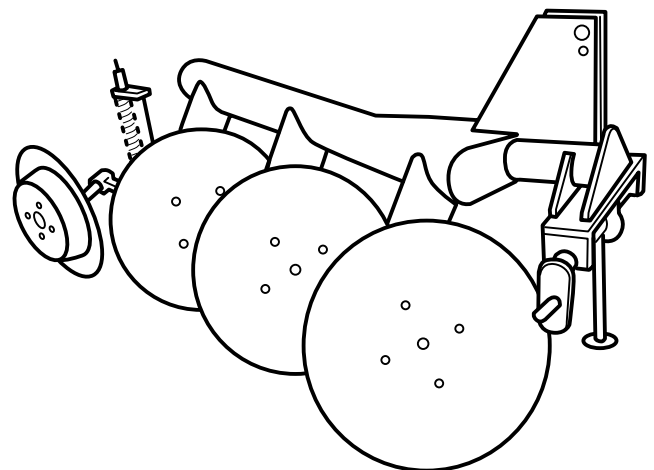
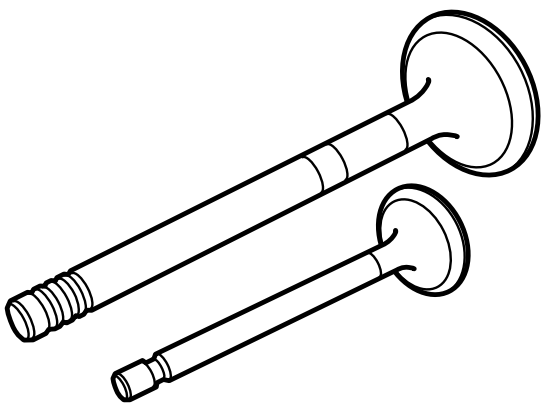



## Surface preparation electrode

| Product Name<br>Classification AWS<br>Classification EN<br>Classification DIN | Mechanical<br>Properties<br>Typical Values | Size<br>(mm)                           | Approvals | Characteristics and Applications  |
|---|--|--|-----------|---|
| <b>UTP VANADIUM 500</b>   | -  | 4.0 X 450<br>5.0 x 450<br>6.0 x 450    | -         | Electrode for hard coatings based on Chrome Carbonates and Vanadium, developed to resist to extreme abrasion and corrosion provoked by the sugarcane milling, washed or not, excusing the "Chevron" and increasing productivity and the helpful life of the sugar mill's cylinders. Spraying with UTP Vanadium 500 makes mill's frieze surface rough in order to improve the "catch", which represents a considerable increase in the tonnage of cane crushed by decreasing the sugar cane slip to minimum rates, providing maximum bagasse use. The special coating of this electrode produces an aggressive arc "spray" type of high penetration, being able to be applied with equipment in milling. High rate of coating on roll surfaces with drops from the exact size to increase the sugar cane traction. UTP VANADIUM 500 works with lower than conventional amperages. Excellent abrasion resistance. |
| <b>LOTUS-740</b>  | Hardness as deposited:<br>180 - 220 BHN    | 3.15 x 350<br>4.0 x 350<br>5.0 x 350   | -         | Predominantly suited for tough and crack resistant overlays. Surfacing on parts of high Mn steel subject to extreme impact, compression and shock. Build-ups of C-steel are also possible. Weld bead is clean, finely rippled and free from slag residue. The high Mn produces fully austenitic deposit which is highly work hardening. Applications: Excavator pins, buckets and teeth, mill hammers, crusher jaws, cones and beaters, impeller bars, Railway building machinery, shunts and cross pieces  |
| <b>LOTUS-750</b>  | Hardness as deposited:<br>62 -65 HRC       | 3.15 x 350<br>4.0 x 350<br>5.0 x 350   | -         | Suitable for steels parts requiring severe abrasion wear resistance. Deposit gives low coefficient of friction during service. Very smooth weld metal transfer. Easy to handle in all positions. Recommended in cement, earthmoving, construction and agriculture industries. Suitable for buttering layer over Lotus -740 of high Mn deposit. Applications: Buckets (pads, lips and teeth), Fan blades, Hammers and scrappers  |
| <b>CUTALOY</b>  | -  | 3.15 x 450<br>4.00 x 450<br>5.00 x 450 | -         | Cutaloy is a medium coated electrode specially designed for faster and smoother cutting, piercing of all types of steels including stainless steel, austenitic manganese steel, cast iron, non ferrous metal in all position. No special skill, supplementary equipment or oxyegn tanks are required.   |
| <b>UTP N 890 AS</b>   | -  | 3.15 x 350<br>4.00 x 350<br>5.00 x 350 | -         | Thick coated chamfering stick electrode UTP N 890 AS can be used on all steel grades with ferritic and austenitic structure, as well as cast iron, cast steel and all non-ferrous metals. It enables workpieces to be grooved out in a very simple way. UTP N 890 AS is also suitable for removing corroded metal layers and for fusion-cutting metallic materials. UTP N 890 AS strikes easily and generates a high gas pressure, enabling a clean and smooth cut to be achieved. Applications: Gouging nonferrous metals including aluminium, cast irons, steels, other metals, bevelling cracks, removing unwanted metal and unwanted sections old rivets etc.   |

# TIG rods for repair of cracked material

## Stainless Steels

| Product Name<br>Classification AWS<br>Classification EN<br>Classification DIN | Mechanical Properties<br>Typical Values                      | Size (mm)  | Approvals | Characteristics and Applications   |
|---|--|--|-----------|--|
| <b>UTP A 651</b><br><br>AWS A5.9:<br>ER 312<br><br>EN ISO 14343-A:<br>W 29 9  | UTS: 750 MPa<br>YS: 650 MPa<br>El: 25%<br>CVN Impact:<br>27J | 1.2 x 1000<br>1.6 x 1000<br>2.0 x 1000<br>2.4 x 1000<br>3.2 x 1000 | -         | UTP A 651 is suitable for joining and surfacing of steels of difficult weldability, repair of hot and cold working steels, cushioning layers. The weld metal of UTP A 651 is scale resistant up to 1150°C. Crack and wear resistant, stainless and work hardening. Hardness of the pure weld metal: approx. 240 HB |

## Copper alloys

| Product Name<br>Classification AWS<br>Classification EN<br>Classification DIN                  | Mechanical Properties<br>Typical Values   | Size (mm)  | Approvals | Characteristics and Applications  |
|--|---|--|-----------|---|
| <b>UTP A 381</b><br><br>AWS A5.7:<br>ER Cu<br><br>EN ISO 24373:<br>S Cu 1898 (CuSn1)           | UTS: 200 MPa<br>YS: 50 MPa<br>El: 30%     | 1.6 x 1000<br>2.0 x 1000<br>2.4 x 1000<br>3.2 x 1000 | -         | UTP A 381 is used for oxygen free copper types according to DIN 1787 OF-Cu, SE-Cu, SW-Cu, SF-Cu. The main applicational fields are in the apparatus- and pipeline construction.   |
| <b>UTP A 387</b><br><br>AWS A5.7:<br>ER CuNi<br><br>EN ISO 24373:<br>S Cu 7158 (CuNi30Mn1FeTi) | UTS: >360 MPa<br>YS: >200 MPa<br>El: >30% | 1.6 x 1000<br>2.0 x 1000<br>2.4 x 1000<br>3.2 x 1000 | TÜV, GL   | UTP A 387 is used for copper nickel alloys with up to 30% nickel according to DIN 17664, such as CuNi20Fe (2.0878), CuNi30Fe (2.0882). Chemical industry, seawater desalination plants, ship building, offshore technique. The weld metal of UTP A 387 is resistant to seawater and cavitation. |

## Nickel Alloys

| Product Name<br>Classification AWS<br>Classification EN<br>Classification DIN                         | Mechanical Properties<br>Typical Values   | Size (mm)   | Approvals               | Characteristics and Applications  |
|---|---|---|-------------------------|---|
| <b>UTP A 068 HH</b><br><br>AWS A5.14:<br>ER NiCr-3<br><br>EN ISO 18274:<br>S Ni 6082 (NiCr20Mn3Nb)    | UTS: >640 MPa<br>YS: >380 MPa<br>El: >35%<br>CVN impact:<br>196° C: 80J           | 1.6 x 1000<br>2.0 x 1000<br>2.4 x 1000<br>3.2 x 1000                                  | TÜV, ABS,<br>DNV GL, CE | UTP A 068 HH is predominantly used for joining identical or similar highly heat-resistant Ni-base alloys, heat-resistant austenites, and for joining heat-resistant austenitic-ferritic materials. UTP A 068 HH can be used for repair welding of hardly weldable steels such as heat-treatable steels or tool steels. Additionally mixed joints of austenitic and ferritic materials with elevated service temperatures can be welded. The welding deposit is hot-cracking-resistant and does not tend to embrittlement.   |
| <b>UTP A 6222 Mo</b><br><br>AWS A5.14:<br>ER NiCrMo-3<br><br>EN ISO 18274:<br>S Ni 6625 (NiCr22Mo9Nb) | UTS: >740 MPa<br>YS: >460 MPa<br>El: >30%<br>CVN Impact:<br>>100J<br>-196°C: >85J | 1.6 x 1000<br>2.0 x 1000<br>2.4 x 1000<br>3.2 x 1000*<br>* available<br>on<br>request | TÜV, GL,<br>DNV, ABS    | UTP A 6222 Mo has a high nickel content and is suitable for welding high strength and high corrosion resistant nickel base alloys. It can be used for joining ferritic steel to austenitic steel as well as for surfacing on steel. It is also possible to weld 9% nickel steels using this wire due to its high yield strength. Its wide range of uses is of particular significance in aviation, in chemical industry and in applications involving seawater. The special features of the weld metal of UTP A 6222 Mo include a good creep rupture strength, corrosion resistance, resistance to stress and hot cracking. |

# Open arc cored wires for repair, anti-wear and anti-corrosion

## Manganese steels

| Product Name<br>Classification AWS<br>Classification EN<br>Classification DIN | Mechanical Properties<br>Typical Values               | Size (mm) | Approvals | Characteristics and Applications  |
|---|---|-----------|-----------|---|
| <b>SK N AP-O</b><br><br>DIN 8555:<br>MF 7-GF-200-KP                           | Hardness as welded: 205 BHN<br>Work hardened: 500 BHN | 2.8       | -         | Multipurpose cored wire mainly used for rebuilding and joining of Carbon and 14% Manganese steels. It can also be used as buffer layer prior to hard overlay. Work-hardenable alloy.<br>Field of use: Railway rails and crossovers, mill shaft drive ends, gyratory crusher mantels, repointing of shovel teeth, buffer layer for inter-particles crushers. |

## Low alloy steels

| Product Name<br>Classification AWS<br>Classification EN<br>Classification DIN | Mechanical Properties<br>Typical Values | Size (mm)                       | Approvals | Characteristics and Applications  |
|---|---|---------------------------------|-----------|---|
| <b>SK BU - O</b><br><br>DIN 8555:<br>MF 1-GF-300-P                            | Hardness as welded: 280 HB              | 1.2<br>1.6<br>2.0<br>2.4<br>2.8 | -         | Rebuilding alloy for Carbon steel parts. It can also be used as buffer layer prior to hard overlay.<br>Field of use: Crawler tractor links, crane wheels, shafts, buffer layer for continuous casting rollers, mine car wheels. |
| <b>SK 260 NbC-O</b><br><br>DIN 8555:<br>MF 6-GF-60                            | Hardness as welded: 60 HRC              | 1.6<br>2.8<br>3.2               | -         | Special crack-free martensitic alloy enhanced with Boron designed to resist high stress abrasive wear.<br>Field of use: Hardbanding of drilling pipes.  |

## High alloyed steels

| Product Name<br>Classification AWS<br>Classification EN<br>Classification DIN | Mechanical Properties<br>Typical Values | Size (mm)         | Approvals | Characteristics and Applications   |
|---|---|-------------------|-----------|--|
| <b>UTP AF VANADIUM 500</b>  | -                                       | 2.0<br>2.4<br>2.8 | -         | Chromium and vanadium flux cored wire in austenitic matrix, especially developed for arcing application in sugar mills rolls. The vanadium carbides which have 30% higher hardness than chromium carbides, improve the abrasion resistance in wet condition. |

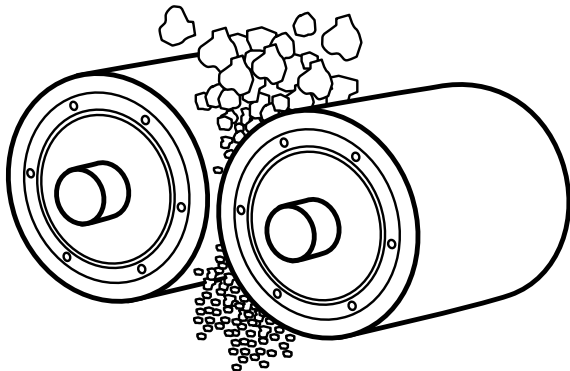

## High alloyed steels

| Product Name<br>Classification AWS<br>Classification EN<br>Classification DIN | Mechanical Properties<br>Typical Values | Size (mm)                       | Approvals | Characteristics and Applications  |
|---|---|---------------------------------|-----------|---|
| <b>SK N 162 - O</b><br><br>DIN 8555:<br>MF 10-GF-65-G                         | Hardness as welded: 62 -64 HRC          | 2.8                             | -         | High Chromium alloy designed to resist high stress grinding abrasion with low impact. The deposit will show readily stress relief cracks.<br>Field of use: Gyrotary crushers cones and mantles, vertical roller mills, coal pulverizer rolls, wear plates, etc.   |
| <b>SK 258 TIC-O</b><br><br>DIN 8555:<br>MF 6-GF-60-GP                         | Hardness as welded: 58 HRC              | 1.2<br>1.6<br>2.0<br>2.4<br>2.8 | -         | Martensitic Chromium-Titanium alloy designed to resist high stress abrasion with heavy impact. Deposits usually do not relieve cracks. Field of use: Crusher rollers, crusher hammers, asphalt mixer blades, agricultural tools, shovel bucket teeth and lips, bulldozer blades, cane knives and shredders, bed knives in the wood pulp industry.   |
| <b>SK A43-O</b><br><br>DIN 8555:<br>MF 10-GF-65-G                             | Hardness as welded: 64 HRC              | 1.6<br>2.0<br>2.4<br>2.8        | -         | CrNb alloy designed to resist high stress grinding abrasion at service temperature not exceeding 450°C. The deposit will readily show stress relief cracks. Field of use: Shovel, excavator, dredge and dragline bucket lips and teeth, hammers, rippers, crushing equipment, wear plates, expeller screws, giratory crushers, etc.   |
| <b>SK N A45-O</b><br><br>DIN 8555:<br>MF 10-GF-65-GT                          | Hardness as welded: 63 HRC              | 2.8                             | -         | Chromium-Niobium-Molybdenum alloy with addition of Tungsten and Vanadium designed to resist high stress grinding abrasion with low impact and solid erosion at service temperatures up to 650°C. The deposits will readily show stress relief cracks.<br>Field of use: Wear plates, sinter finger crushers, exhaust fan blades in pellet plants, perlite crushers, bucket teeth and lips on bucket wheel excavators, boiler fan blades, burden area in blast furnace bells, etc.    |
| <b>SK ABRA - MAX O/G</b><br><br>DIN 8555:<br>MF 6-GF-70-GT                    | Hardness as welded: 70 HRC              | 1.6<br>2.0<br>2.4<br>2.8        | -         | Special hardfacing cored wire designed to give an extreme resistance against high stress grinding abrasion and erosion without impact. The typical mechanical properties can be achieved in the first layer. The deposit will readily show stress relief cracks. Shielding gas: Argon + 2% Oxygen (if not used as open arc). Field of use: Conveyors screws, crusher plates and rolls, shredder teeth, fan blades, bucket teeth and lips, agricultural machinery, wear plates, etc. |

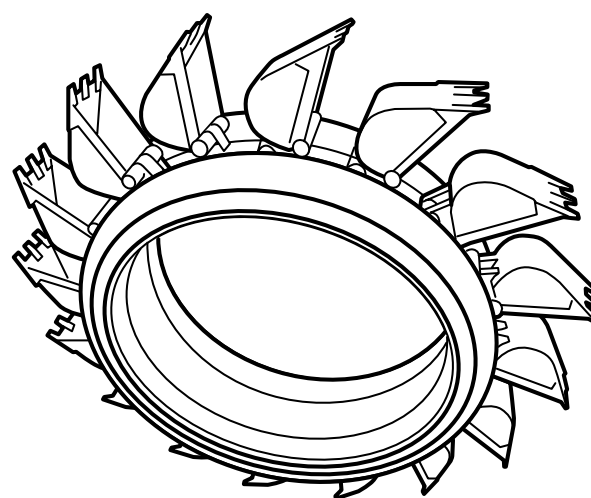
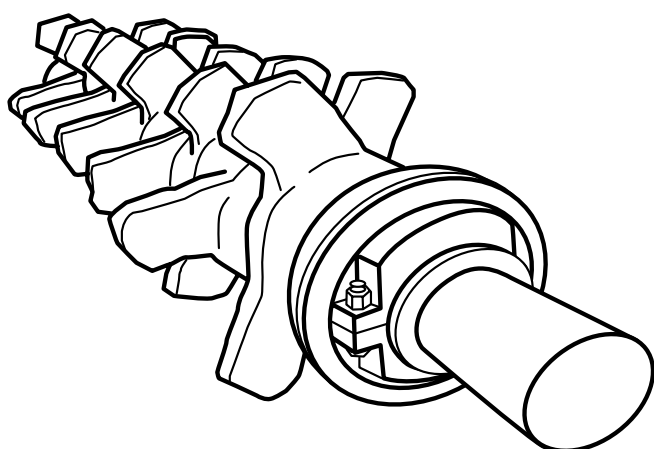

## Submerged arc cored wires for anti-wear and anti-corrosion

| Product Name<br>Classification AWS<br>Classification EN<br>Classification DIN | Mechanical Properties<br>Typical Values   | Size (mm)  | Approvals | Characteristics and Applications  |
|---|---|------------|-----------|---|
| <b>SK-C 430C-SA</b><br><br>DIN 8555:<br>UP 5-GF-200-C                         | Hardness as welded: 170 HB (160 – 200 HB) | 3.2        | -         | Alloy depositing a ferritic steel containing 17% Chromium designed to resist corrosion at high temperatures, particularly in presence of sulphurous gas.<br>Field of use: Continuous casting rollers situated at the top of the line, valves, steam and gas turbine parts, valve seats. |
| <b>SK-C 742N-SK</b><br><br>DIN 8555:<br>UP 5-GF-45-C                          | Hardness as welded: 40 HRC (37 to 42 HRC) | 2.4<br>3.2 | -         | Alloy depositing a ferritic-martensitic steel with addition of Nitrogen designed to enhance the resistance to thermal fatigue and intragranular corrosion by reducing the formation of carbides at grain boundaries.<br>Field of use: Continuous casting rollers.                       |
| <b>SK 242-S</b><br><br>DIN 8555:<br>UP 1-GF-40-P                              | Hardness as welded: 40 HRC                | 3.2        | -         | Submerged arc surfacing wire for rebuilding and hard surfacing alloy of Carbon steel parts subjected to adhesive wear with impacts.<br>Field of use: Crawler tractor rollers and idlers, shafts, cylinders, mine car wheels, crane wheels.  |
| <b>SK 258 NbC-SA</b><br><br>DIN 8555:<br>UP 6-GF-60-G                         | Hardness as welded: 57 HRC                | 3.2        | -         | Sub-arc flux-cored wire designed to deposit a crack-free martensitic alloy.<br>Field of use: Inter-particles crusher rollers.   |

## Submerged arc welding fluxes for anti-wear and anti-corrosion

| Product Name<br>Classification AWS<br>Classification EN<br>Classification DIN | Main (mm)  | Characteristics and Applications   |
|---|--|--|
| <b>RECORD SK</b><br><br>EN 760:<br>SA FB 3                                    | Grain size:<br>0.4 – 1.4 mm<br>(14 x 40 N° ASTM) | Special agglomerated flux for hardfacing with high Nitrogen containing flux cored wire as SK 742N-SK. Very good slag removal and weld bead appearance make this flux particularly suitable for the hardfacing of continuous casting rolls. |
| <b>RECORD SA</b><br><br>EN 760:<br>SA FB 3                                    | Grain size:<br>0.4 – 1.4 mm<br>(14 x 40 N° ASTM) | Highly basic agglomerated flux designed for hardfacing with cored wires or solid wires. Very good slag removal even at high welding intensity levels. Suitable with DC or AC.  |

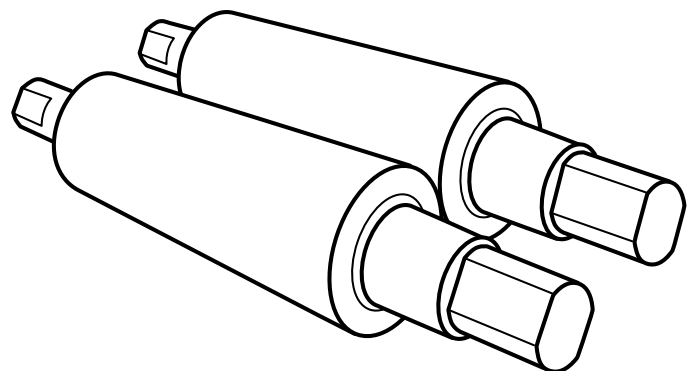



# JOIN! voestalpine Böhler Welding

We are a leader in the welding industry with over 100 years of experience, more than 50 subsidiaries and more than 4,000 distribution partners around the world. Our extensive product portfolio and welding expertise combined with our global presence guarantees we are close when you need us. Having a profound understanding of your needs enables us to solve your demanding challenges with Full Welding Solutions - perfectly synchronized and as unique as your company.



**Lasting Connections** – Perfect alignment of welding machines, consumables and technologies combined with our renowned application and process know-how provide the best solution for your requirements: A true and proven connection between people, products and technologies. The result is what we promise: Full Welding Solutions for Lasting Connections.



**Tailor-Made Protectivity™** – The combination of our high-quality products and application expertise enables you to not only repair and protect metal surfaces and components. Our team of engineers, experienced in your specific applications, offer you customized solutions resulting in increased productivity for your demanding challenge. The result is what we promise: Tailor-Made Protectivity™.



**In-Depth Know-How** – As a manufacturer of soldering and brazing consumables, we offer proven solutions based on 60 years of industrial experience, tested processes and methods, made in Germany. This in-depth know-how makes us the internationally preferred partner to solve your soldering and brazing challenge through innovative solutions. The result is what we promise: Innovation based on in-depth know-how.

The Management System of voestalpine Böhler Welding Group GmbH, Peter-Mueller-Strasse 14-14a, 40469 Duesseldorf, Germany has been approved by Lloyd's Register Quality Assurance to: ISO 9001:2015, ISO 14001:2015, OHSAS 18001:2007, applicable to: Development, Manufacturing and Supply of Welding and Brazing Consumables. More information: [www.voestalpine.com/welding](http://www.voestalpine.com/welding)



**Delhi Office**

Office No. 201D, 2<sup>nd</sup> Floor,  
D-21, Corporate Park, Sector-21,  
Near Dwarka Sector-8 Metro Station,  
Dwarka, New Delhi - 110 075  
India

**Factory**

SP-183, RIICO Industrial Area,  
Kaharani, Bhiwadi, Dist. Alwar,  
Rajasthan - 301 019  
India  
T. +91 1493-298268

**Application Technology Centre**

A-140, Metropolitan, Ground Floor,  
Road No. 23, Wagle Industrial Estate,  
Thane (West) - 400 604  
India  
T. +91 22 2582 8855/56

**voestalpine Bohler Welding India Pvt. Ltd.**

A-140, Metropolitan, Road No. 23,  
Wagle Industrial Estate,  
Thane (West) - 400 604, Maharashtra,  
India  
T: +91 22 4228 4400  
E: [welding.india@voestalpine.com](mailto:welding.india@voestalpine.com)  
[www.voestalpine.com/welding](http://www.voestalpine.com/welding)

**voestalpine**

ONE STEP AHEAD.